

Speedy with fine-pitch thread

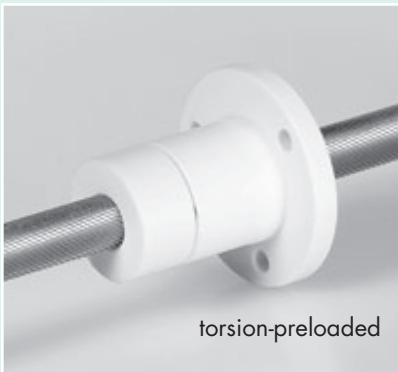

Standard flange nut, non-preloaded/preloaded

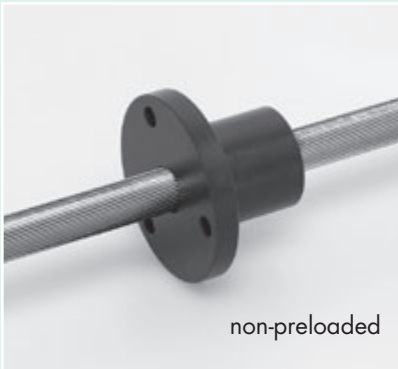

Legend

d_0 = nominal screw diameter [mm]

d_2 = core diameter [mm]

p_0 = nominal pitch [mm]

p = effective pitch [mm]

i = number of threads [-]

C_{stat} = static load rates for non-preloaded POM-C or preloaded EX100 nuts [N];
for higher load rates, bronze nuts must be used ($C_{stat\ bronze} = 1.3 \times C_{stat\ POM/EX100}$)

B = bronze CuSn12, material N° 2.1052

³⁾ = only on request

⁶⁾ = not available with torsion-preload

Special designs available on request.

All specifications are subject to change without notice.

Quality management ISO 9001:2008



Speedy with fine-pitch thread

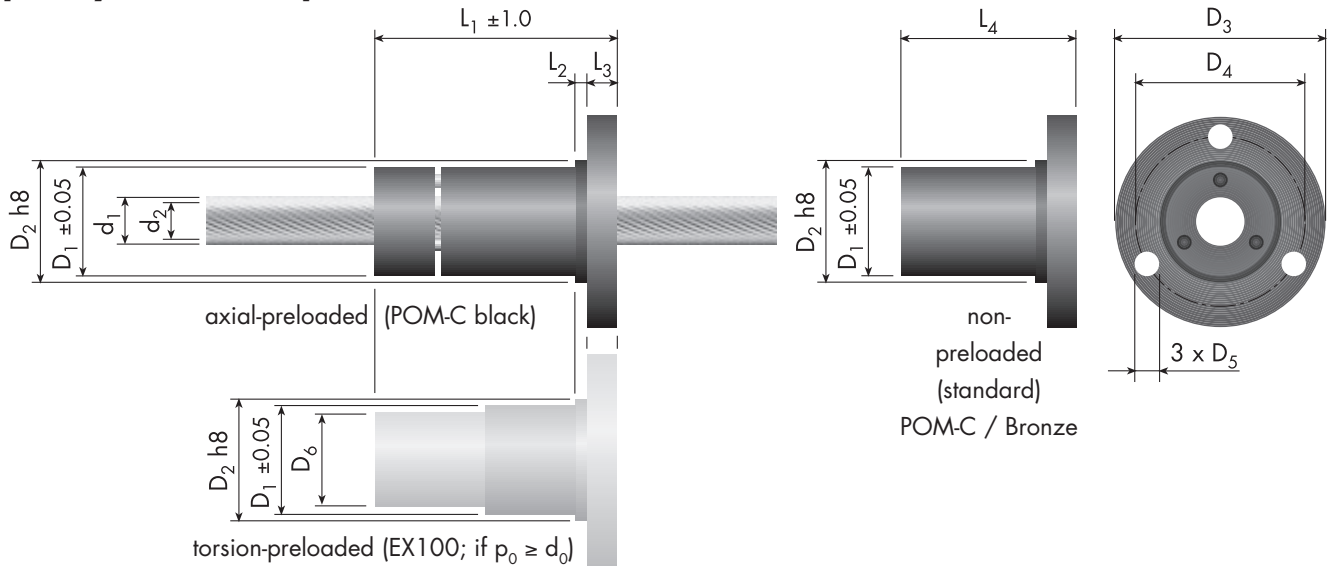

Speedy d_0 / p_0 mm	Dimensions											Load rates				
	Screw				Nut							POM / B		C_{stat} for POM/EX100 N		
	d_1	d_2	p	i	D_1 ± 0.05	D_2 h8	D_3	D_4 hole circle	D_5	D_6	L_1	L_2	L_3	L_4		
right-hand threads																
4 / 10	4.0	3.0	10	8	11.5	12	28	18	3.2	—	—	3	4	20 / —	150	
5 / 5	5.4	3.6	5	4	20.5	21	38	29	4.2	18.5	38	3	5	25 / 18	300	
5 / 20	6.0	5.0	20	16	20.5	21	38	29	4.2	18.5	38	3	5	25 / 18	300	
6 / 25	7.4	6.3	25	20	20.5	21	38	29	4.2	18.5	38	3	5	25 / 18	400	
7.5 / 7.5	7.7	5.9	7.5	6	20.5	21	38	29	4.2	18.5	38	3	5	25 / 18	450	
8 / 30	8.6	7.5	30	24	20.5	21	38	29	4.2	18.5	38	3	5	25 / 18	500	
10 / 10	10.0	8.2	10	8	23.5	24	42	32	4.2	21.5	38	3	5	25 / 18	600	
10 / 35	10.1	8.9	35	28	23.5	24	42	32	4.2	21.5	38	3	5	25 / 18	600	
11 / 40	11.5	10.2	40	32	23.5	24	42	32	4.2	21.5	38	3	5	25 / 18	700	
12 / 45	12.8	11.4	45	36	23.5	24	42	32	4.2	21.5	38	3	5	25 / 18	800	
12.5 / 12.5 ³⁾	12.3	10.4	12.5	10	23.5	24	42	32	4.2	21.5	38	3	5	25 / 18	750	
left-hand threads																
5 / 20	6.0	5.0	20	16	20.5	21	38	29	4.2	18.5	38	3	5	25 / 18	300	
8 / 30	8.6	7.5	30	24	20.5	21	38	29	4.2	18.5	38	3	5	25 / 18	500	
10 / 35	10.1	8.9	35	28	23.5	24	42	32	4.2	21.5	38	3	5	25 / 18	600	
12 / 45	12.8	11.4	45	36	23.5	24	42	32	4.2	21.5	38	3	5	25 / 18	800	

The CAD data corresponding to the types shown above are available at www.gewinde.ch